

Device Incorporation Concept

HTX Accelerator Card for Reconfigurable Computing

Michael Aitken
 Supervisor: Prof M. Ingg
 Co-Supervisor: Dr A. Langman

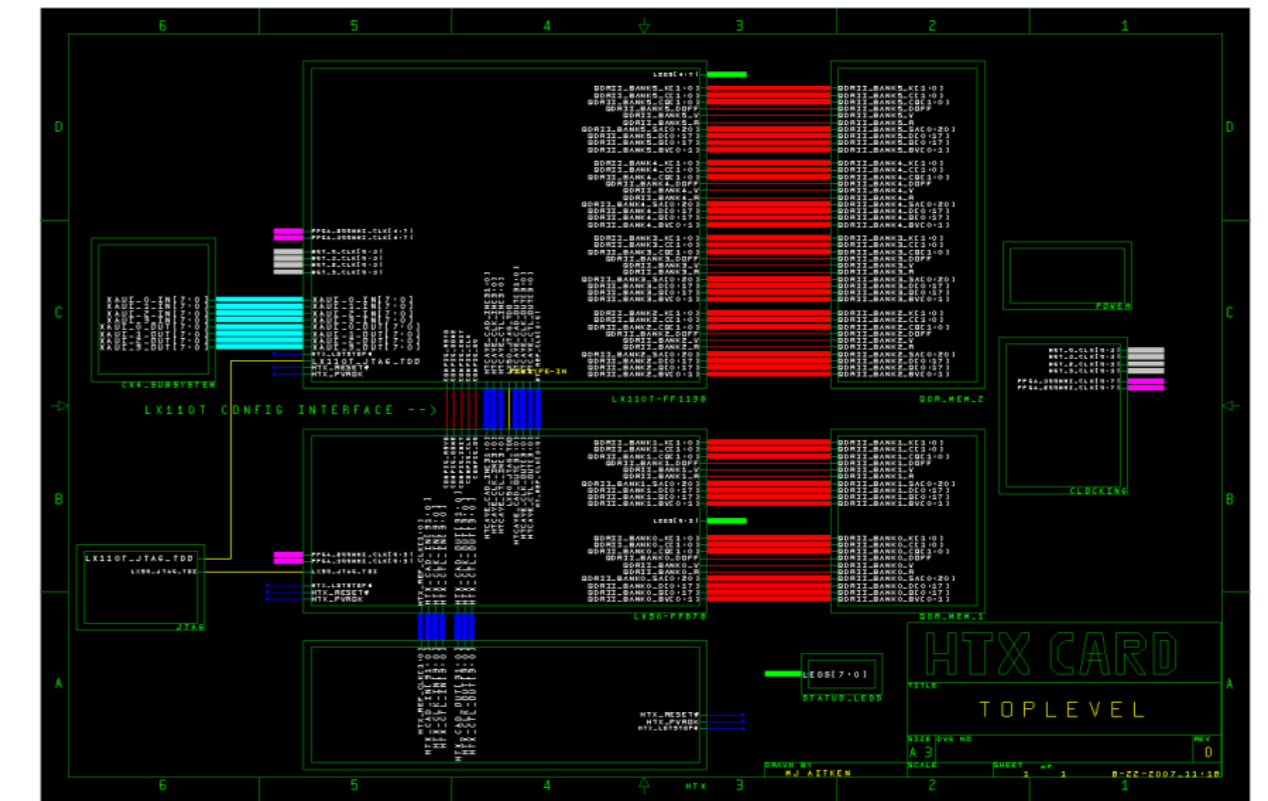

Top Level Schematic Design

Background

- Reconfigurable computing promises to provide the flexibility and performance that general high performance computing currently lacks.
- The key to adding reconfigurability to a computing system is to have a plug-in reconfigurable co-processing device.
- Such a device could be used in both server-farm and desktop computing systems to boost processing intensive, parallel operations.
- Paralleizable operations can be exported to the reconfigurable co-processor whilst everything else is executed by the general purpose CPU.

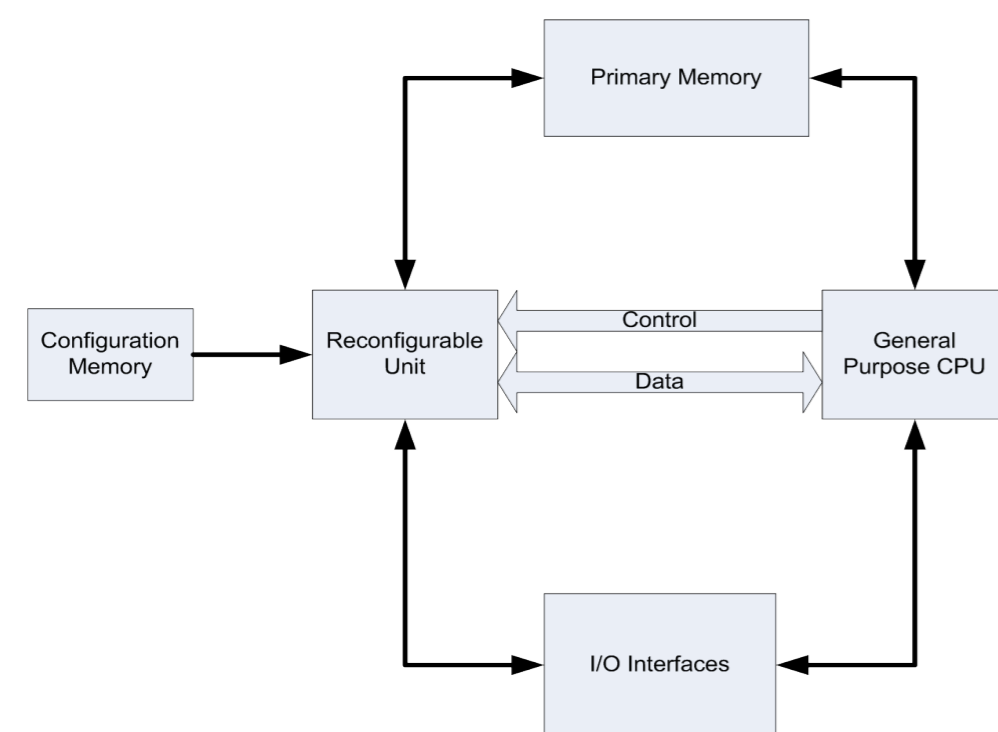

Reconfigurable Co-processor Concept

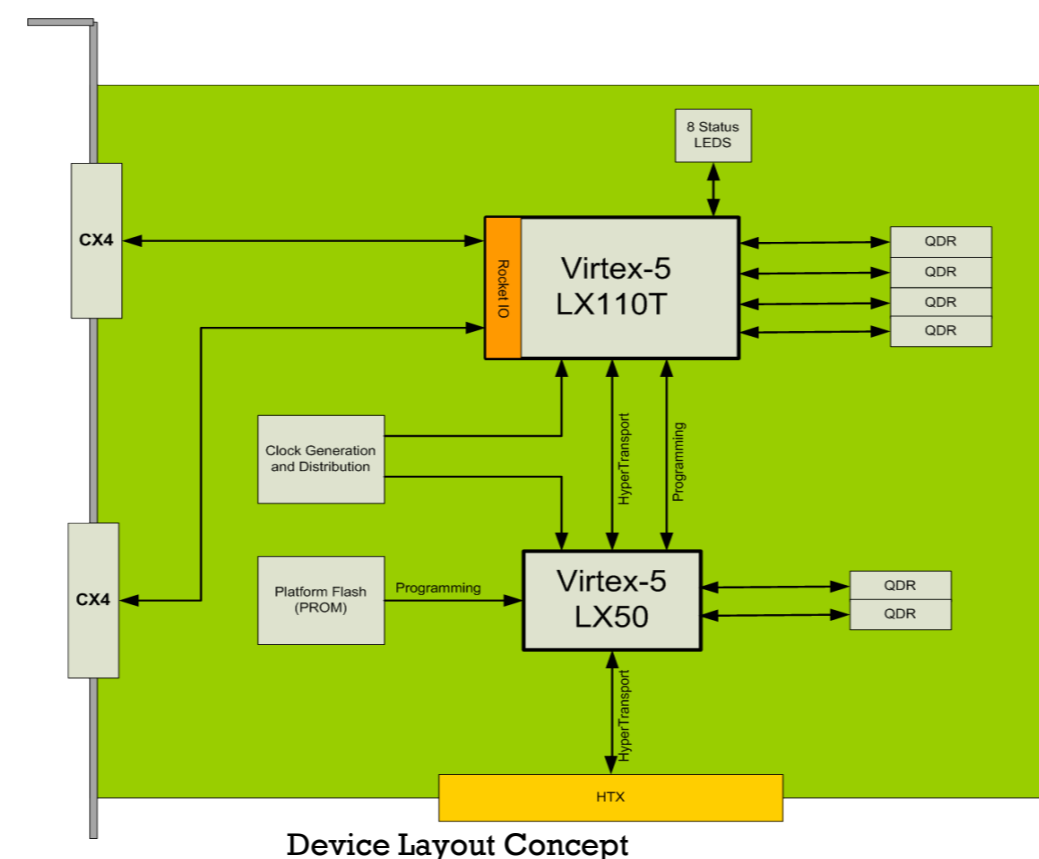

Device Layout Concept

Funding By:
 SKA/KAT
 Centre for High Performance Computing

Motivation

- Existing reconfigurable accelerator cards are extremely expensive and as a result a scalable reconfigurable computing system may be out of the scope of many projects.
- Existing products were designed with the previous generation of FPGA devices which have been replaced by smaller, faster, more power efficient devices.
- Newer faster standards for I/O interconnects such as 10Gigabit Ethernet or InfiniBand remain mostly unexploited.
- It would be beneficial for the local HPC industry to make use of a South African made accelerator card with which to build a scalable high performance reconfigurable computer.

Key Objectives

- Investigate a suitable hardware architecture to provide a reconfigurable computing platform for South African researchers.
- Analyze existing accelerator products.
- Investigate the I/O requirements of a reconfigurable expansion card.
- Using CAD tools, design and fabricate such a device that will use the latest available FPGA technologies.
- Incorporate the device into a conventional desktop computing system.
- Implement a set of drivers and other software to unlock the functionality of the device.



Radar Remote Sensing Group
 Dept. Electrical Engineering, University of Cape Town
 Private Bag, Rondebosch, 7701, South Africa
<http://www.uct.ac.za>

